



bar

actubar[®]
The intelligent actuator



Safe and Flexible –
The new Actuator Generation actubar



Type AD-001



Type AD/AS-004 to AD/AS-230



Type AD/AS-350 to AD/AS-750

Objective

actubar is the latest generation in our range of pneumatic actuators. Externally unmistakable and technically unique, the actubar offers new advantages and uses.

Technically speaking, actubar is the main component in the novel valve control system bar-vacontrol.

A modular, intelligent system for monitoring and regulating automatic valves.

Working together with our directly-mountable system components bar-positurn2 or bar-positurnswitch, actubar regulates quarter-turn valves economically and effectively.



Benefits / Applications



- the unique construction of the actubar enables the addition of components acc. to VDI/VDE 3847 without hose connections or conduit.
- positioner and limit switch boxes with solenoid valves can be mounted directly, without conduit installation and constitute a compact unit in combination with actubar-actuators
- the standard interface (VDI / VDE 3845) allows mounting of all commercially available signal units
- end position can be adjusted at 0° and 90° from +5° to -10°
- reduced warehousing by using equal end-caps for single as well as double-acting actuators in the sizes 004 to 230
- simple insertion and removal of safety springs
- flexible automation of valves through various ISO flange interfaces per actuator size
- optional coatings and materials enable usage even in aggressive environments
- long service life via plain-bearing system which reaches all moving parts
- octagonal pinion-connection enables actubar to fit universally onto valves with parallel or diagonally operating shafts
- blowout-secure pinion minimizes the danger of accidents
- wide spectrum of application through supply of different pivoting angle possibilities

Technical Data

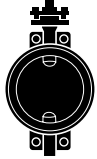
	Standard model	Options available
Description	pneumatic double piston actuator type AD = double-acting type AS = single-acting (with spring return)	
Constructional features	rack and pinion principle with self-centering piston guides in the housing; single-acting: with bar safety springs	
Mounting position	as desired	
Standards	Interface actuator signal unit: acc. to VDI/VDE 3845 (NAMUR) and VDI/VDE 3847 Interface actuator/control valve: acc. to NAMUR i.e. VDI/VDE 3845 Interface actuator/valve: 4, i.e. 8 internal threaded in actuator housing acc. to EN ISO 5211	differing mounting and connecting dimensions possible pinion optional with internal double-D or acc. to DIN ISO 5211
Directives	ATEX, Machine Guidelines	
Materials	Housing: Aluminium alloy, anodised Caps: Aluminium alloy Pistons/Racks: Aluminium alloy Pinion: Corrosion-protected steel Seals: NBR Bearings: self-lubricating plastic Screws: stainless steel A2	Housing: anodised, powder-coated, PTFE Caps: PTFE Pinion: stainless steel AISI 303; AISI 316 Seals: FKM
Ambient temperature	-20°C to +80°C	low-temperature model: -40° C to +80° C high-temperature model: 20° C to +160° C
Rated pivoting angle	double and single-acting: 90° rated pivoting angle as standard from +5° to -10° adjustable in both end positions	
Torque	2.5 Nm to 6,000 Nm	
Control pressure	2 to 8 bar	
Control medium / Quality	filtered air in respect of remaining oil content, dust and water minimum according to DIN ISO 8573-1 / class 4	also upon request: other non-aggressive gaseous or liquid mediums

Mounting Variations

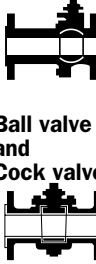
2/2-way-valve	Drive Pinion	Function	Mounting Type
	Double D = Z (upon request) 	single-acting spring force closed	A
		single-acting spring force open	D
	Octagonal = V 	single-acting spring force closed	F
		single-acting spring force open	H

2/2-way-valve	Drive Pinion	Function	Mounting Type
	Double D = Z (upon request) 	single-acting spring force closed	A
		single-acting spring force open	D
	Octagonal = V 	single-acting spring force closed	F
		single-acting spring force open	H

Function – double-acting

When pressure is applied to both of the external chambers through input connection „4“, then the pistons move together into the basic position (0°). The force from both pistons is transferred onto the pinion „C“ via the toothed rack. If input connection „2“ is given pressure and „4“ as exhaust, then the pistons move apart into the 90° position.

In both positions, the pivoting angle can be set via the adjusting screws „D“ to a position of $+5^\circ$ and -10° in a depressurised condition. When the correct angle is reached, then fix with locking nut „E“.

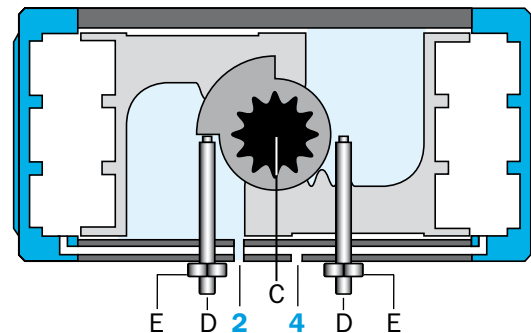
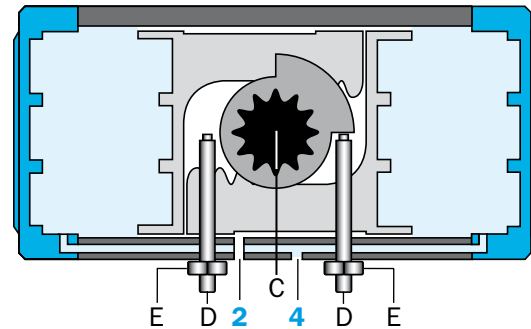
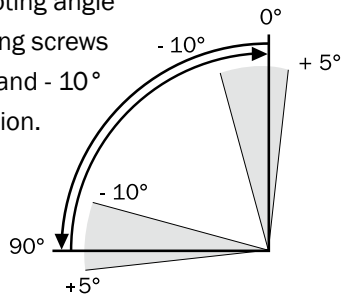

Torque for double-acting actuators, Type AD [Nm]

Type	Control pressure P_{st} [bar]										
	2	2,5	3	3,5	4	4,5	5	5,5	6	7	8
AD - 001	2,5	3,2	3,8	4,4	5,1	5,7	6,4	7,0	7,6	8,9	10,2
AD - 004	8	10	12	14	16	18	20	22	24	28	32
AD - 006	13	16	19	22	25	28	32	35	38	44	51
AD - 008	16	20	24	28	32	36	40	44	48	56	64
AD - 011	23	29	35	40	46	52	58	63	69	81	92
AD - 018	36	45	54	63	72	81	90	99	108	126	144
AD - 026	52	65	78	91	104	117	130	143	156	182	208
AD - 037	74	93	111	129	148	166	185	204	222	259	296
AD - 050	100	125	150	175	200	225	250	275	300	350	400
AD - 076	152	190	228	266	304	342	380	418	456	532	608
AD - 110	220	275	330	385	440	495	550	605	660	770	880
AD - 160	323	403	484	565	645	726	807	887	968	1129	1290
AD - 230	463	579	695	811	927	1043	1159	1274	1390	1622	1854
AD - 350	680	850	1020	1190	1360	1530	1700	1870	2040	2380	2720
AD - 510	1022	1278	1533	1789	2044	2300	2555	2811	3066	3577	4088
AD - 750	1504	1880	2256	2632	3008	3384	3760	4136	4512	5264	6016

Function – single-acting

In the single-acting model the springs push the pistons back into the basic position and air is exhausted from connection „2“.

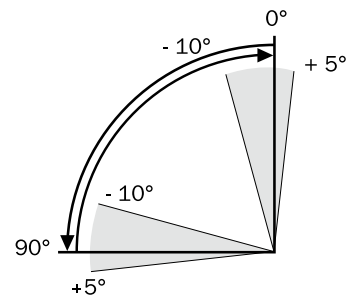
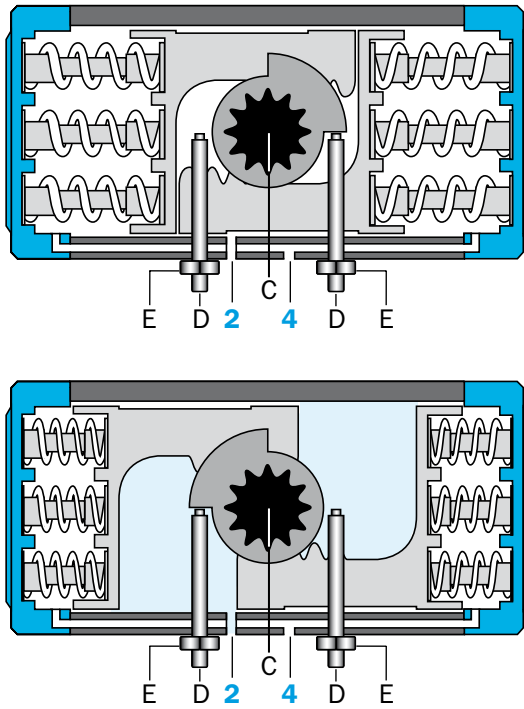

The number of springs can be selected to correspond to the applied pressure (from 2 up to 14 pcs.).

Adjustment of the end positions is described in “Function double-acting”

Torques – single-acting actuators, type AS [Nm]

Type	No. springs	Spring force Md F [Nm]		Pneumatic applied torque Md N [Nm] at min. control pressure P _{St} [bar]																							
		Md min	Md max	2,0		2,5		3,0		3,5		4,0		4,5		5,0		5,5		6,0		7,0		8,0			
				min	max	min	max	min	max	min	max	min	max	min	max	min	max	min	max	min	max	min	max	min	max	min	max
AS-004	2	1	3	5	7	7	9	9	11	11	12	13	14	15	16	17	18	19	20	21	22	25	26	29	30		
	4	3	5	3	5	5	7	7	9	9	11	10	13	12	15	14	17	16	19	18	21	22	25	26	29		
	6	4	8			2	6	4	8	6	10	8	12	10	14	12	16	14	18	16	20	20	24	24	28		
	8	5	11					1	7	3	9	5	10	7	12	9	14	11	16	13	18	17	22	21	26		
	10	7	13							1	7	3	9	4	11	6	13	8	15	10	17	14	21	18	25		
12	8	16											2	10	4	12	6	14	8	16	12	20	16	24			
AS-006	2	2	4	8	11	12	14	15	17	18	20	21	23	24	26	27	30	31	33	34	36	40	42	46	48		
	4	4	8	4	8	7	12	11	15	14	18	17	21	20	24	23	27	26	31	30	34	36	40	42	46		
	6	6	13			3	10	6	13	10	16	13	19	16	22	19	25	22	28	25	32	32	38	38	44		
	8	8	17					2	11	5	14	8	17	12	20	15	23	18	26	21	30	27	36	34	42		
	10	11	21							1	12	4	15	7	18	11	21	14	24	17	27	23	34	30	40		
12	13	25											3	16	6	19	10	22	13	25	19	32	25	38			
AS-008	3	5	8	8	12	12	16	16	20	20	24	24	28	28	32	32	36	36	40	40	44	48	52	56	60		
	4	6	11	5	10	9	14	13	18	17	22	21	26	25	30	29	34	33	38	37	42	45	50	53	58		
	5	8	14	2	9	6	13	10	17	14	21	18	25	22	29	26	33	30	37	34	41	42	49	50	57		
	6	9	17			3	11	7	15	11	19	15	23	19	27	23	31	27	35	31	39	39	47	47	55		
	7	11	20					4	14	8	18	12	22	16	26	20	30	24	34	28	38	36	46	44	54		
	8	12	22					2	12	6	16	10	20	14	24	18	28	22	32	26	36	34	44	42	52		
	9	14	25							3	15	7	19	11	23	15	27	19	31	23	35	31	43	39	51		
	10	15	28											4	17	8	21	12	25	16	29	20	33	28	41		
	11	17	31											1	16	5	20	9	24	13	28	17	32	25	40		
	12	18	34													2	18	6	22	10	26	14	30	22	38		
	13	20	36															4	21	8	25	12	29	20	37		
	14	21	39															1	19	5	23	9	27	17	35		
	AS-011	3	6	12	11	17	17	23	23	29	28	34	34	40	40	46	46	52	51	57	57	63	69	75	80	86	
4		8	16	7	15	13	21	19	27	24	32	30	38	36	44	42	50	47	55	53	61	65	73	76	84		
5		10	20	3	13	9	19	15	25	20	30	26	36	32	42	38	48	43	53	49	59	61	71	72	82		
6		12	24			5	17	11	23	16	28	22	34	28	40	34	46	39	51	45	57	57	69	68	80		
7		14	28			1	15	7	21	12	26	18	32	24	38	30	44	35	49	41	55	53	67	64	78		
8		16	31					4	19	9	24	15	30	21	36	27	42	32	47	38	53	50	65	61	76		
9		18	35							5	22	11	28	17	34	23	40	28	45	34	51	46	63	57	74		
10		20	39							1	20	7	26	13	32	19	38	24	43	30	49	42	61	53	72		
11		22	43									3	24	9	30	15	36	20	41	26	47	38	59	49	70		
12		24	47											5	28	11	34	16	39	22	45	34	57	45	68		
13		26	51											1	26	7	32	12	37	18	43	30	55	41	66		
14		28	55													3	30	8	35	14	41	26	53	37	64		
AS-018		3	9	18	18	27	27	36	36	45	45	54	54	63	63	72	72	81	81	90	90	99	108	117	126	135	
		4	12	24	12	24	21	33	30	42	39	51	48	60	57	69	66	78	75	87	84	96	102	114	120	132	
	5	15	30	6	21	15	30	24	39	33	48	42	57	51	66	60	75	69	84	78	93	96	111	114	129		
	6	18	36			9	27	18	36	27	45	36	54	45	63	54	72	63	81	72	90	90	108	108	126		
	7	21	42			3	24	12	33	21	42	30	51	39	60	48	69	57	78	66	87	84	105	102	123		
	8	24	48					6	30	15	39	24	48	33	57	42	66	51	75	60	84	78	102	96	120		
	9	27	54							9	36	18	45	27	54	36	63	45	72	54	81	72	99	90	117		
	10	30	60							3	33	12	42	21	51	30	60	39	69	48	78	66	96	84	114		
	11	33	66									6	39	15	48	24	57	33	66	42	75	60	93	78	111		
	12	36	72											9	45	18	54	27	63	36	72	54	90	72	108		
	13	39	78											3	42	12	51	21	60	30	69	48	87	66	105		
	14	42	84													6	48	15	57	24	66	42	84	60	102		
	AS-026	3	13	27	25	39	38	52	51	65	64	78	77	91	90	104	103	117	116	130	129	143	155	169	181	195	
		4	17	35	17	35	30	48	43	61	56	74	69	87	82	100	95	113	108	126	121	139	147	165	173	191	
5		21	44	8	31	21	44	34	57	47	70	60	83	73	96	86	109	99	122	112	135	138	161	164	187		
6		26	53			12	40	25	53	38	66	51	79	64	92	77	105	90	118	103	131	129	157	155	183		
7		30	62			3	35	16	48	29	61	42	74	55	87	68	100	81	113	94	126	120	152	146	178		
8		34	71					7	44	20	57	33	70	46	83	59	96	72	109	85	122	111	148	137	174		
9		38	80							11	53	24	66	37	79	50	92	63	105	76	118	102	144	128	170		
10		43	89							2	49	15	62	28	75	41	88	54	101	67	114	93	140	119	166		
11		47	98									6	57	19	70	32	83	45	96	58	109	84	135	110	161		
12		51	106											11	66	24	79	37	92	50	105	76	131	102	157		
13		55	115													2	62	15	75	28	88	41	101	67	127	93	153
14		60	124															6	71	19	84	32	97	58	123	84	149

Type	No. springs	Spring force Md F [Nm]		Pneumatic applied torque Md N [Nm] at min. control pressure P _{St} [bar]																							
		Md min	Md max	2,0		2,5		3,0		3,5		4,0		4,5		5,0		5,5		6,0		7,0		8,0			
				min	max	min	max	min	max	min	max	min	max	min	max	min	max	min	max	min	max	min	max	min	max	min	max
AS-037	3	21	40	34	53	53	72	71	90	89	108	108	127	126	145	145	164	163	182	182	201	219	238	256	275		
	4	27	53	21	47	40	66	58	84	76	102	95	121	113	139	132	158	150	176	169	195	206	232	243	269		
	5	34	66	8	40	27	59	45	77	63	95	82	114	100	132	119	151	137	169	156	188	193	225	230	262		
	6	41	80			13	52	31	70	49	88	68	107	86	125	105	144	123	162	142	181	179	218	216	255		
	7	48	93					18	63	36	81	55	100	73	118	92	137	110	155	129	174	166	211	203	248		
	8	55	106					5	56	23	74	42	93	60	111	79	130	97	148	116	167	153	204	190	241		
	9	62	119							10	67	29	86	47	104	66	123	84	141	103	160	140	197	177	234		
	10	69	133									15	79	33	97	52	116	70	134	89	153	126	190	163	227		
	11	75	146									2	73	20	91	39	110	57	128	76	147	113	184	150	221		
	12	82	159											7	84	26	103	44	121	63	140	100	177	137	214		
	13	89	173													12	96	30	114	49	133	86	170	123	207		
	14	96	186															17	107	36	126	73	163	110	200		
	AS-050	3	28	53	47	72	72	97	97	122	122	147	147	172	172	197	197	222	222	247	272	297	322	347	372		
		4	37	71	29	63	54	88	79	113	104	138	129	163	154	188	179	213	204	238	229	263	279	313	329	363	
5		46	88	12	54	37	79	62	104	87	129	112	154	137	179	162	204	187	229	212	254	262	304	312	354		
6		56	106			19	69	44	94	69	119	94	144	119	169	144	194	169	219	194	244	244	294	294	344		
7		65	124					26	85	51	110	76	135	101	160	126	185	151	210	176	235	226	285	276	335		
8		74	142					8	76	33	101	58	126	83	151	108	176	133	201	158	226	208	276	258	326		
9		83	159							16	92	41	117	66	142	91	167	116	192	141	217	191	267	241	317		
10		93	177									23	107	48	132	73	157	98	182	123	207	173	257	223	307		
11		102	195									5	98	30	123	55	148	80	173	105	198	155	248	205	298		
12		111	212											13	114	38	139	63	164	88	189	138	239	188	289		
13		121	230													20	129	45	154	70	179	120	229	170	279		
14		130	248															27	145	52	170	102	220	152	270		
AS-076		3	42	80	72	110	110	148	148	186	186	224	224	262	262	300	300	338	338	376	376	414	452	490	528	566	
		4	56	107	45	96	83	134	121	172	159	210	197	248	235	286	273	324	311	362	349	400	425	476	501	552	
	5	70	134	18	82	56	120	94	158	132	196	170	234	208	272	246	310	284	348	322	386	398	462	474	538		
	6	84	161			29	106	67	144	105	182	143	220	181	258	219	296	257	334	295	372	371	448	447	524		
	7	98	188			2	92	40	130	78	168	116	206	154	244	192	282	230	320	268	358	344	434	420	510		
	8	112	214					14	116	52	154	90	192	128	230	166	268	204	306	242	344	318	420	394	496		
	9	126	241							25	140	63	174	101	216	139	254	177	292	215	330	291	406	367	482		
	10	140	268									36	164	74	202	112	240	150	278	188	316	264	392	340	468		
	11	154	295									9	150	47	188	85	226	123	264	161	302	237	378	313	454		
	12	168	321											21	174	59	212	97	250	135	288	211	364	287	440		
	13	183	348													32	197	70	235	108	273	184	349	260	425		
	14	197	375													5	183	43	221	81	259	157	335	233	411		
	AS-110	3	66	116	104	154	159	209	214	264	269	319	324	374	379	429	434	484	489	539	544	594	654	704	764	814	
		4	88	155	65	132	120	187	175	242	230	297	285	352	340	407	395	462	450	517	505	572	615	682	725	792	
5		110	193	27	110	82	165	137	220	192	275	247	330	302	385	357	440	412	495	467	550	577	660	687	770		
6		132	232			43	143	98	198	153	253	208	308	263	363	318	418	373	473	428	528	538	638	648	748		
7		154	271			4	121	59	176	114	231	169	286	224	341	279	396	334	451	389	506	499	616	609	726		
8		176	309					21	154	76	209	131	264	186	319	241	374	296	429	351	484	461	594	571	704		
9		197	348							37	188	92	243	147	298	202	353	257	408	312	463	422	573	532	683		
10		219	387									53	221	108	276	163	331	218	386	273	441	383	551	493	661		
11		241	425									15	199	70	254	125	309	180	364	235	419	345	529	455	639		
12		263	464											31	232	86	287	141	342	196	397	306	507	416	617		
13		285	503													47	265	102	320	157	375	267	485	377	595		
14		307	541													9	243	64	298	119	353	229	463	339	573		
AS-160		3	84	160	162	239	243	319	323	400	404	481	485	561	565	642	646	723	727	803	807	884	969	1045	1130	1207	
		4	112	214	109	211	189	292	270	372	351	453	431	534	512	614	593	695	673	775	754	856	915	1017	1076	1179	
	5	140	267	55	183	136	264	216	344	297	425	378	506	458	586	539	667	620	748	700	828	862	989	1023	1151		
	6	168	321			82	236	163	316	244	397	324	478	405	558	486	639	566	720	647	800	808	962	969	1123		
	7	195	374					109	288	190	369	271	450	351	530	432	611	513	692	593	772	755	934	916	1095		
	8	223	428					56	261	137	341	217	422	298	502	379	583	459	664	540	744	701	906	862	1067		
	9	251	481							83	313	164	394	244	475	325	555	406	636	486	717	648	878	809	1039		
	10	279	535									110	366	191	447	272	527	352	608	433	689	594	850	756	1011		
	11	307	588											137	419	218	499	299	580	379	661	541	822	702	983		
	12	335	642													165	471	245	552	326	633	487	794	649	955		
	13	363	695															192	524	272	605	434	766	595	927		
	14	391	749																	219	577	380	738	542	900		

Type	No. springs	Spring force		Pneumatic applied torque Md N [Nm] at min. control pressure P _{St} [bar]																							
		Md F [Nm]		2,0		2,5		3,0		3,5		4,0		4,5		5,0		5,5		6,0		7,0		8,0			
		min	max	min	max	min	max	min	max	min	max	min	max	min	max	min	max	min	max	min	max	min	max	min	max		
AS-230	3	128	221	242	335	358	451	474	567	590	683	706	799	822	915	938	1030	1053	1146	1169	1262	1401	1494	1633	1725		
	4	171	295	169	293	285	408	400	524	516	640	632	756	748	872	864	988	980	1103	1096	1219	1327	1451	1559	1683		
	5	214	368	95	250	211	366	327	482	443	597	559	713	674	829	790	945	906	1061	1022	1177	1254	1408	1485	1640		
	6	256	442	21	207	137	323	253	439	369	555	485	671	601	786	717	902	832	1018	948	1134	1180	1366	1412	1597		
	7	299	516			64	280	180	396	295	512	411	628	527	744	643	860	759	975	875	1091	1106	1323	1338	1555		
	8	342	589					106	353	222	469	338	585	453	701	569	817	685	933	801	1048	1033	1280	1264	1512		
	9	384	663					32	311	148	427	264	542	380	658	496	774	611	890	727	1006	959	1237	1191	1469		
	10	427	737						74	384		190	500	306	616	422	731	538	847	654	963	885	1195	1117	1426		
	11	470	810									117	457	232	573	348	689	464	804	580	920	812	1152	1043	1384		
	12	513	884											159	530	275	646	390	762	506	878	738	1109	970	1341		
	13	555	958													201	603	317	719	433	835	664	1067	896	1298		
	14	598	1031															243	676	359	792	591	1024	822	1256		
	AS-350	3	189	342	338	491	508	661	678	831	848	1001	1018	1171	1188	1341	1358	1511	1528	1681	1698	1851	2038	2191	2378	2531	
		4	253	456	224	427	394	597	564	767	734	937	904	1107	1074	1277	1244	1447	1414	1617	1584	1787	1924	2127	2264	2467	
5		316	571	110	364	280	534	450	704	620	874	790	1044	960	1214	1130	1384	1300	1554	1470	1724	1810	2064	2150	2404		
6		379	685			165	471	335	641	505	811	675	981	845	1151	1015	1321	1185	1491	1355	1661	1695	2001	2035	2341		
7		442	799					221	578	391	748	561	918	731	1088	901	1258	1071	1428	1241	1598	1581	1938	1921	2278		
8		505	913							277	685	447	855	617	1025	787	1195	957	1365	1127	1535	1467	1875	1807	2215		
9		568	1027									333	792	503	962	673	1132	843	1302	1013	1472	1353	1812	1693	2152		
10		631	1141											389	899	559	1069	729	1239	899	1409	1239	1749	1579	2089		
11		695	1255													445	1005	615	1175	785	1345	1125	1685	1465	2025		
12		758	1369															501	1112	671	1282	1011	1622	1351	1962		
13		821	1483																	557	1219	897	1559	1237	1899		
14		884	1597																	443	1156	783	1496	1123	1836		
AS-510		3	272	496	526	750	782	1005	1037	1261	1293	1516	1548	1772	1804	2027	2059	2283	2315	2538	2570	2794	3081	3305	3592	3816	
		4	363	661	361	659	616	915	872	1170	1127	1426	1383	1681	1638	1937	1894	2192	2149	2448	2405	2703	2916	3214	3427	3725	
	5	454	826	196	568	451	824	707	1079	962	1335	1218	1590	1473	1846	1729	2101	1984	2357	2240	2612	2751	3123	3262	3634		
	6	545	992	30	478	286	733	541	989	797	1244	1052	1500	1308	1755	1563	2011	1819	2266	2074	2522	2585	3033	3096	3544		
	7	635	1157			121	642	376	898	632	1153	887	1409	1143	1664	1398	1920	1654	2175	1909	2431	2420	2942	2931	3453		
	8	726	1322					211	807	466	1063	722	1318	977	1574	1233	1829	1488	2085	1744	2340	2255	2851	2766	3362		
	9	817	1487					46	716	301	972	557	1227	812	1483	1068	1738	1323	1994	1579	2249	2090	2760	2601	3271		
	10	908	1653							136	881	391	1137	647	1392	902	1648	1158	1903	1413	2159	1924	2670	2435	3181		
	11	998	1818									226	1046	482	1301	737	1557	993	1812	1248	2068	1759	2579	2270	3090		
	12	1089	1983									61	955	316	1211	572	1466	827	1722	1083	1977	1594	2488	2105	2999		
	13	1180	2148											151	1120	407	1375	662	1631	918	1886	1429	2397	1940	2908		
	14	1271	2314													241	1285	497	1540	752	1796	1263	2307	1774	2818		
	AS-750	3	407	721	783	1097	1159	1473	1535	1849	1911	2225	2287	2601	2663	2977	3039	3353	3415	3729	3791	4105	4543	4857	5295	5609	
		4	543	961	543	961	919	1337	1295	1713	1671	2089	2047	2465	2423	2841	2799	3217	3175	3593	3551	3969	4303	4721	5055	5473	
5		679	1202	302	825	678	1201	1054	1577	1430	1953	1806	2329	2182	2705	2558	3081	2934	3457	3310	3833	4062	4585	4814	5337		
6		815	1442			438	1065	814	1441	1190	1817	1566	2193	1942	2569	2318	2945	2694	3321	3070	3697	3822	4449	4574	5201		
7		951	1682					574	1305	950	1681	1326	2057	1702	2433	2078	2809	2454	3185	2830	3561	3582	4313	4334	5065		
8		1086	1923							709	1546	1085	1922	1461	2298	1837	2674	2213	3050	2589	3426	3341	4178	4093	4930		
9		1222	2163											845	1786	1221	2162	1597	2538	1973	2914	2349	3290	3101	4042	4853	4794
10		1358	2403											605	1650	981	2026	1357	2402	1733	2778	2109	3154	2861	3906	3613	4658
11		1494	2644													740	1890	1116	2266	1492	2642	1868	3018	2620	3770	3372	4522
12		1630	2884															876	2130	1252	2506	1628	2882	2380	3634	3132	4386
13		1765	3124																	1012	2371	1388	2747	2140	3499	2892	4251
14		1901	3365																	771	2235	1147	2611	1899	3363	2651	4115

Dimensioned drawings for actubar types AD/AS-001 to AD/AS-006

Typ AD-001

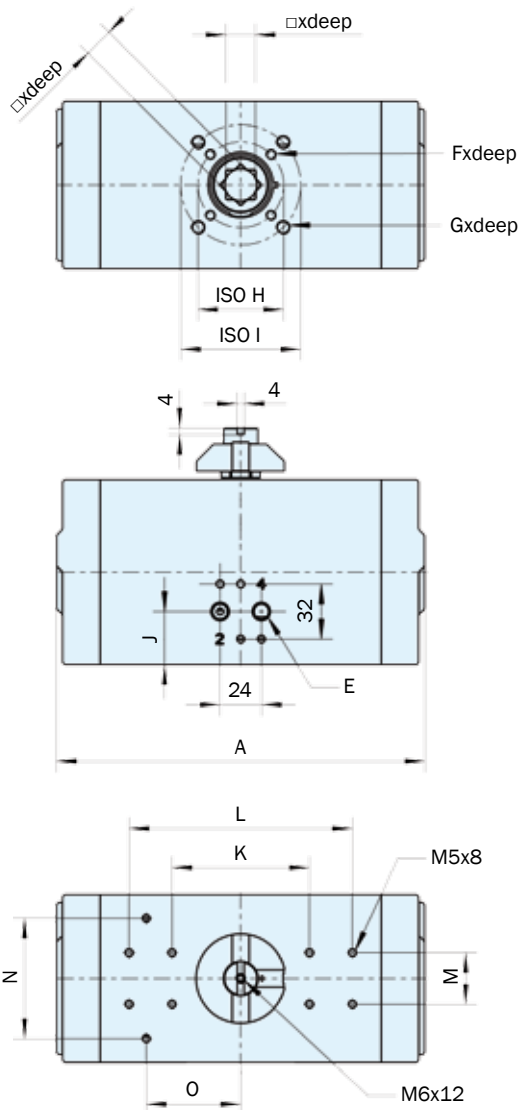
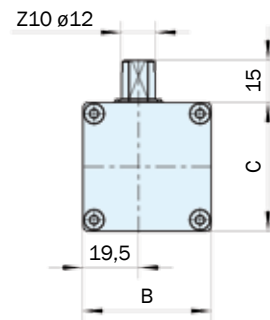

Typ AD/AS-004 and AD/AS-006

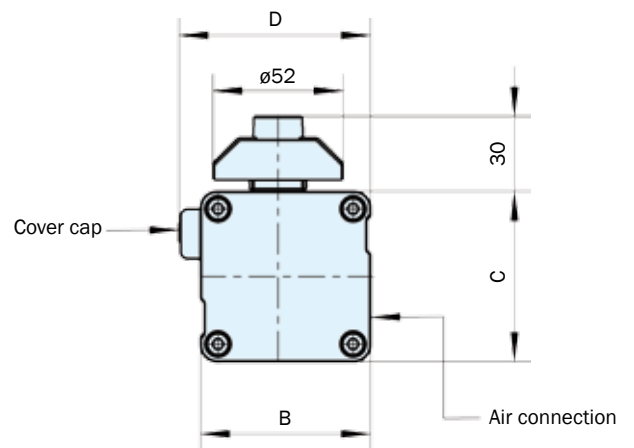

Dimensioned drawing for actubar type AD/AS-008 to AD/AS-230

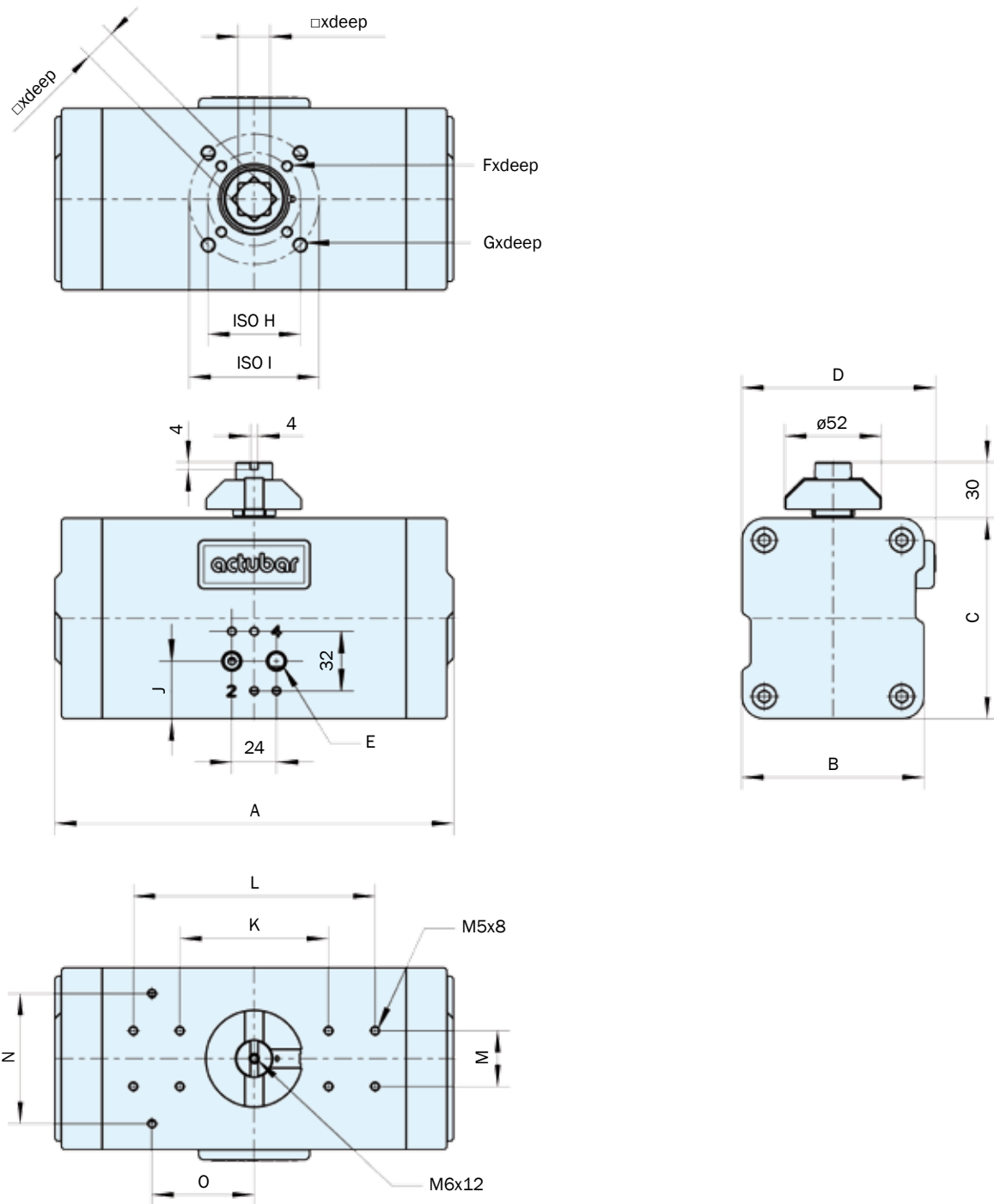

Dimensioned drawing for actubar type AD/AS-350 to AD/AS-750

Type AD/AS-350 to AD/AS-510

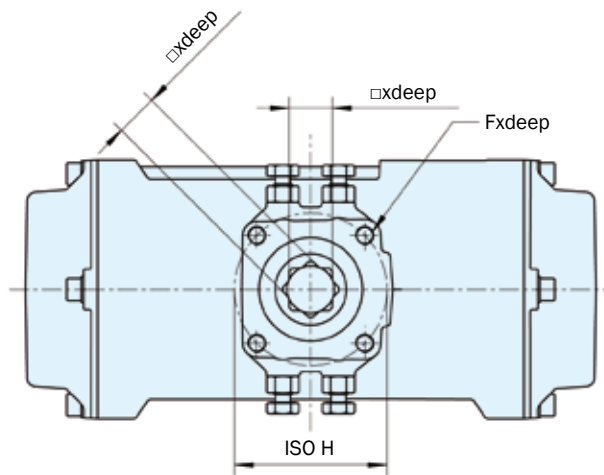

Type AD/AS-750

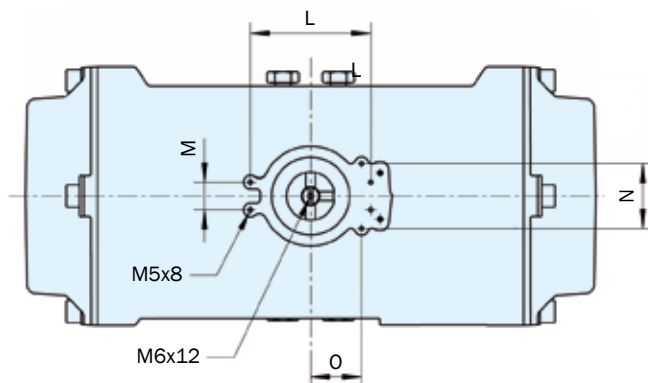
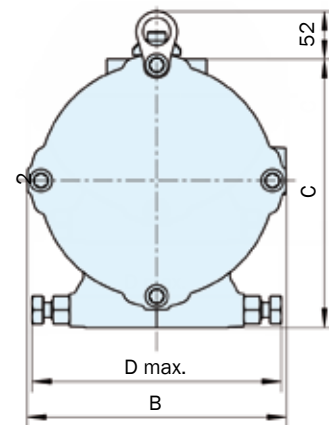
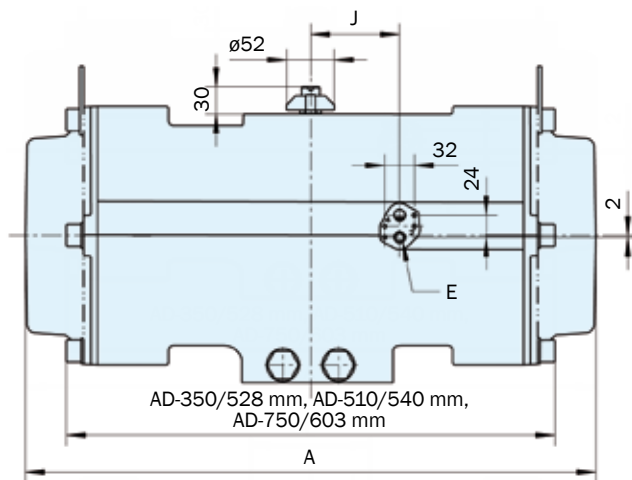
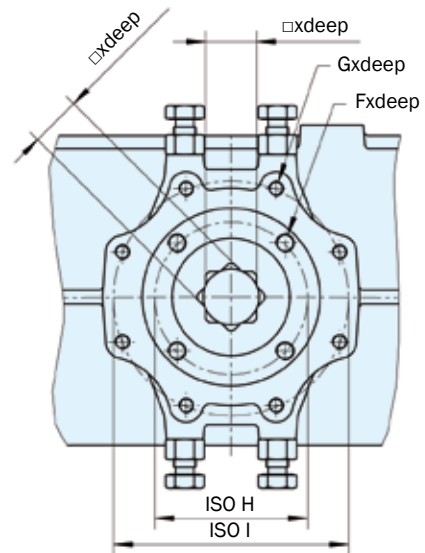

Table of Dimensions

Type AD/AS	A	B	C	D	E	Fxdeep	Gxdeep	ISO H	ISO I	J	K	L	M	N	O	□xdeep
001	80	45	45		G 1/8"	M5x8		ø36/F03		22,5	50		25			9x12
004	144	68	68	82	G 1/8"	M5x8	M6x9	ø36/F03	ø50/F05	24	80		30			14x17
006	159	76	84	90	G 1/8"	M6x9	M8x12	ø50/F05	ø70/F07	32	80		30			14x17
008	173	98	108	109	G 1/8"	M6x9	M8x12	ø50/F05	ø70/F07	31	80		30			14x17
011	215	98	108	109	G 1/8"	M6x9	M8x12	ø50/F05	ø70/F07	31	80	130	30	70	55	17x20
018	213	114	132	127	G 1/4"	M6x9	M8x12	ø50/F05	ø70/F07	35	80	130	30	70	55	17x20
026	281	114	132	127	G 1/4"	M8x12	M10x15	ø70/F07	ø102/F10	35	80	130	30	70	55	22x25
037	266	138	161	155	G 1/4"	M8x12	M10x15	ø70/F07	ø102/F10	40,5	80	130	30	70	55	22x25
050	347	138	161	155	G 1/4"	M8x12	M10x15	ø70/F07	ø102/F10	40,5	80	130	30	70	55	22x25
076	329	176	200	196	G 1/4"	M10x15	M12x18	ø102/F10	ø125/F12	50	80	130	30	70	55	27x30
110	475	176	200	196	G 1/4"	M10x15	M12x18	ø102/F10	ø125/F12	50	80	130	30	70	55	27x30
160	516	199	220	225	G 1/4"	M10x15	M12x18	ø102/F10	ø125/F12	60	80	130	30	70	55	27x30
230	560	223	244	249	G 1/4"	M16x24		ø140/F14		72	80	130	30	70	55	36x40
350	617	280	290	275	G 1/4"	M20x40		ø165/F16		96		130	30	70	55	46x50
510	732	330	341	310	G 1/4"	M20x40		ø165/F16		96		130	30	70	55	46x50
750	826	368	430	425	G 1/4"	M20x40	M16x35	ø165/F16	ø125/F25	109		130	30	70	55	46x60

Double-acting actuators

Type AD	Weight [kg]	Volume/Double-stroke [L]
001	0,34	0,05
004	1,21	0,25
006	1,81	0,41
008	2,97	0,60
011	3,59	0,85
018	4,80	1,35
026	6,27	1,78
037	8,23	2,75
050	11,25	3,73
076	15,90	5,50
110	22,94	8,50
160	27,46	11,90
230	38,10	16,90
350	40,60	19,00
510	59,20	30,00
750	90,00	42,50

Single-acting actuators

Type AS	Weight* [kg]	Volume/Double-stroke [L]
004	1,38	0,09
006	2,04	0,19
008	3,13	0,20
011	3,89	0,33
018	5,28	0,50
026	6,93	0,73
037	9,43	1,15
050	12,81	1,63
076	18,66	2,30
110	27,02	3,50
160	33,30	4,80
230	45,20	7,00
350	50,00	9,60
510	85,00	15,00
750	125,00	20,50

* weight at 12 springs

Parts AD/AS-004 to AD/AS-230

- | | | | | |
|-----------------|-----------------|---------------------|-------------------------|------------------------------|
| 1 Cover cap | 6 End cap seal | 11 Namur shaft | 16 O-Ring | 21 Lock-nut |
| 2 End-stop cam | 7 Threaded pin | 12 Visual display | 17 Piston guidance ring | 22 Lower sliding ring |
| 3 Ring clip | 8 O-Ring | 13 Piston | 18 Upper sliding ring | 23 Cap screw |
| 4 End cap left | 9 Housing | 14 Guidance segment | 19 Pinion | 24 O-Ring |
| 5 End cap right | 10 Threaded pin | 15 O-Ring | 20 Spring | 25 Washer |
| | | | | 26 Position indication balls |

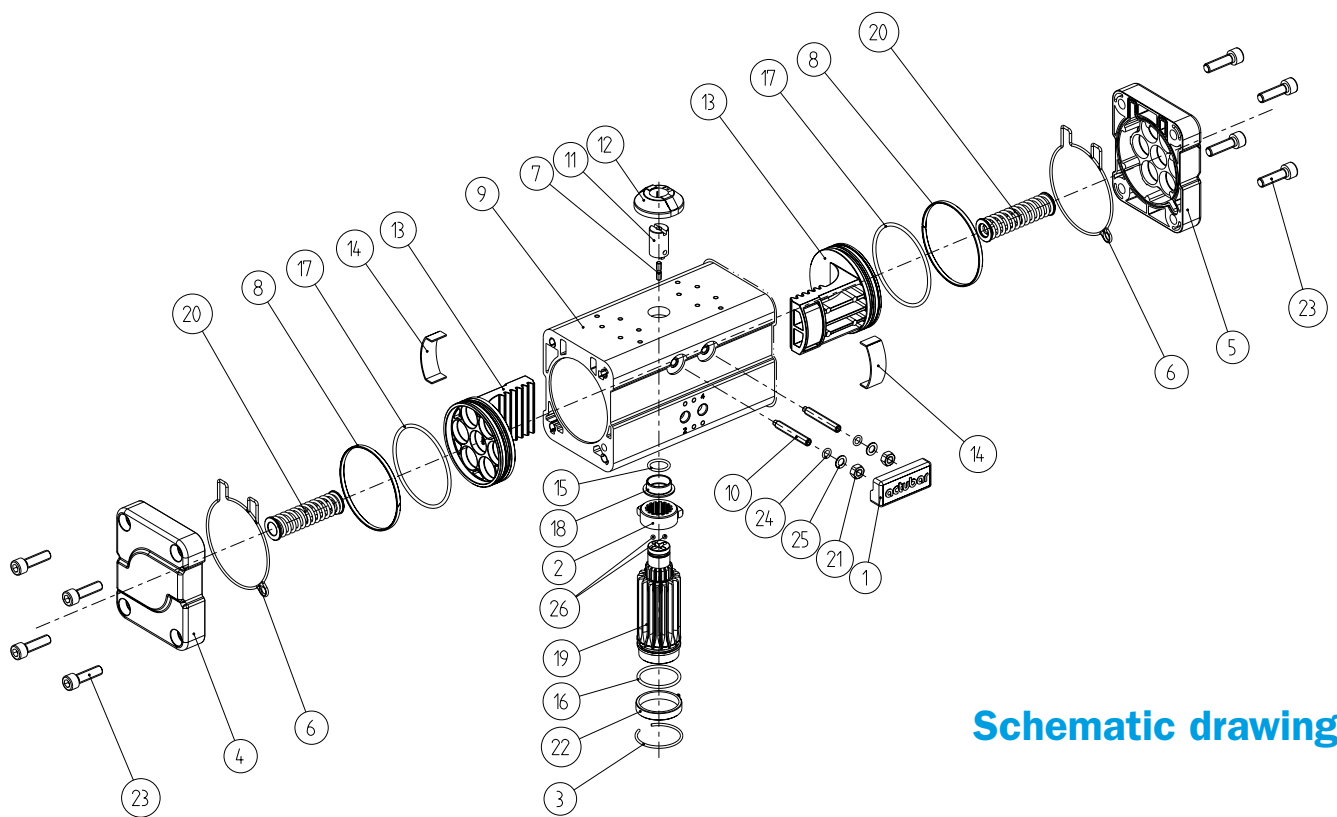

Schematic drawing

Ordering Code (example)

A	S	-	0	5	0	/	0	9	0	-	0	8	-	V22	F
A	D	-	0	5	0	/	0	9	0	-			-	Z...	A
Function			Type				Pivoting angle 90°				No. springs			Pinion model *	Mounting type
S = single D = double														*	Page 3

* **V** = octagonal with measurements **Z** = double-D with dimensions given

Parts AD/AS-350 to AD/AS-750

1 Cover cap	7 Threaded pin	13 Piston	19 Pinion	25 Washer
2 End-stop cam	8 O-Ring	14 Guidance segment	20 Spring	26 Position indication balls
3 Ring clip	9 Housing	15 O-Ring	21 Lock-nut	27 Suspension eye
4 End cap left	10 Threaded pin	16 O-Ring	22 Lower sliding ring	28 Cover ring
5 End cap right	11 Namur shaft	17 Piston guidance ring	23 Cap screw	29 Screws
6 End cap seal	12 Visual display	18 Upper sliding ring	24 O-Ring	

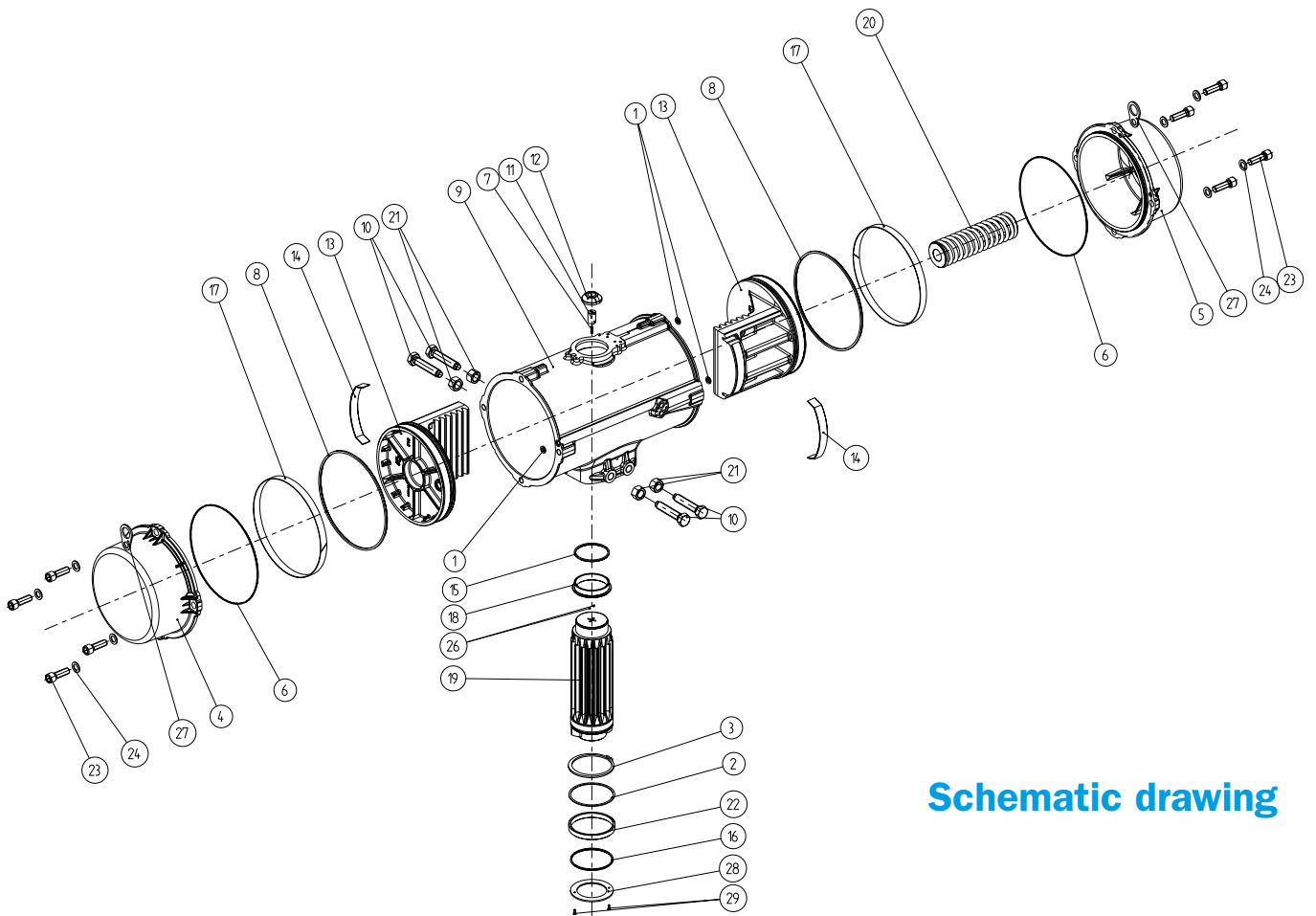

Schematic drawing

Interfaces

Actubar as center of the Vacotrol system possesses interfaces according to all standards. Modular construction enables combinations with the following products from our extensive range as well as all other commercially available positioners, solenoid valves and valve fittings.

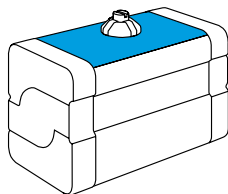

Interface actuator/signal unit acc. to VDI/VDE 3845



bar-switchcontrol



bar-miniswitch



bar-switchmaster

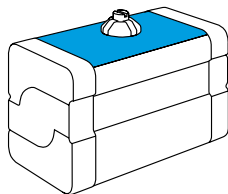

Interface actuator/signal unit bar-vacotrol



bar-positum2



bar-positiswitch

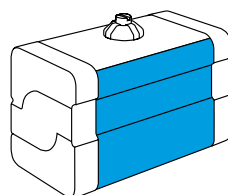

Interface actuator/control valve to VDI/VDE 3845 Namur



bar-solenoid valve



Multibar (pressure booster)



Throttle plate

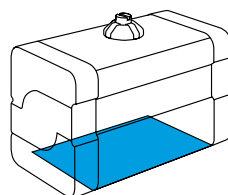

Interface actuator/valve acc. to DIN EN ISO 5211



Manual override



Reductions



Adapters

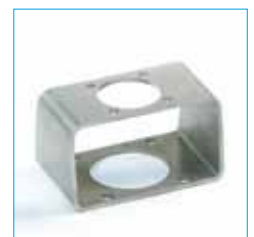

Mounting brackets

bar GmbH

Auf der Hohl 1
53547 Dattenberg/Germany

Tel. +49 (0) 2644 - 96070
Fax +49 (0) 2644 - 960735

www.bar-gmbh.de
sales@bar-gmbh.de

www.bar-gmbh.de
